

STRUCTURE SURVEY TEMPLATE







				DATE	10-22-08
ROAD NAME	Structure #1, #2, #3			COUNTY	LA
STREAM NAME	South Fork SCR			PHOTO ID #	
STRUCTURE #	Drop str. #1, #2, & #3		X,Y COORDINATE		
TYPE	LENGTH	SIZE (W X H) & SHAPE	MATERIAL	Road to Bed	INLET/OUTLET TYPE
Railroad Bridge				Top of Road EL	
SPECIAL NOTE (Conditions, Blockage, etc)					
HIGH WATER MARK (Description, Witness, and Date)					
TYPE		CULVERT TYPE	MATERIAL	Road to Bed	INLET/OUTLET TYPE
Bridge Span Bridge Pier Shape Culvert Dam Millway Trestle Barrel Outlet		Number of Barrels 1) Circular 2) Rectangle (Span X Rise) 3) Elliptical 4) Con/Span 5) Elevated Arch 6) Pipe Arch 7) Other	RCP (Reinforced Concrete Pipe) CMP (Corrugated Metal Pipe) Bitmus Coated Steel Timber Ductile Clay Masonry Rock	Height from Top of Road to Invert Top of Road EL From Topo Map (FT.NGVD) or (FT.NAVD)	Headwall Wingwalls Type 0°, 45°, 90° Projecting Flush with Slope MES (Mitered End Section) FES (Flared End Section)

Pier Shape

- 1) Circular pier
- 2) Twin-Cylinder piers
- 3) Elongated pier
- 4) Triangular nose
- 5) Square nose



Types (Shape) of Culvert

- | | | |
|---|---|---|
|  |  |  |
| 1) Circular | 2) Rectangle | 3) Elliptical |
|  |  |  |
| 4) Con/Span | 5) Elevated Arch | 6) Pipe Arch |
| 7) Other | | |

Inlet/Outlet Type

Culvert with Headwall & Wingwalls

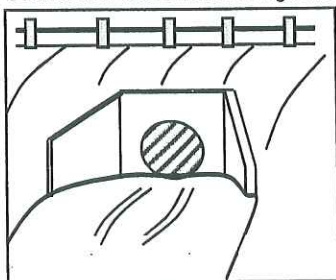

Mitered to Conform to Slope

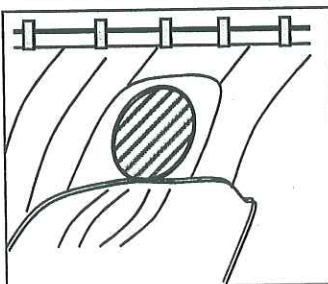

Projecting from Fill

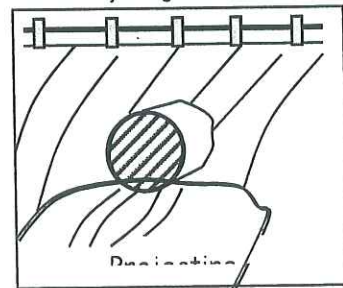

CHANNEL INFORMATION

ROAD TO BANK	CHANNEL TOP WIDTH	CHANNEL BOTTOM WIDTH

BRIDGE INFORMATION

DECK THICKNESS	TOP WIDTH	TOE WIDTH
HYDRAULIC WIDTH	NUMBER OF PIERS	PIER THICKNESS

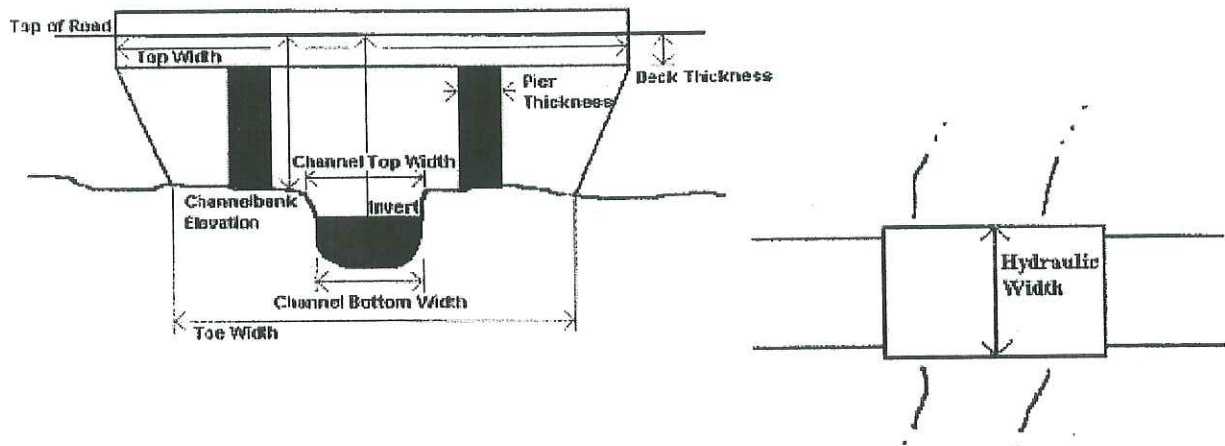

PHOTOS

Name

Description

--	--	--

ADDITIONAL CHANNEL INFORMATION

Land Use

Vegetative Cover

Bed Material

General Channel Condition

Banks

Overbanks

STRUCTURE SURVEY TEMPLATE







				DATE	10-22-08
AD NAME	Lyons Ave.			COUNTY	LA
STREAM NAME	South Fork SCR			PHOTO ID #	
STRUCTURE #	3 4	X,Y COORDINATE			
TYPE	LENGTH	SIZE (W X H) & SHAPE	MATERIAL	Road to Bed	INLET/OUTLET TYPE
Railroad Bridge				Top of Road EL	
SPECIAL NOTE (Conditions, Blockage, etc)		2 Box Culvs. / No measurement			
HIGH WATER MARK (Description, Witness, and Date)		Baffle blocks @ DS side			
TYPE		CULVERT TYPE	MATERIAL	Road to Bed	INLET/OUTLET TYPE
Bridge Span Bridge Pier Shape <u>Culvert</u> Dam Millway Trench Barrel Outlet		Number of Barrels 2 1) Circular 2) <u>Rectangle</u> (Span X Rise) 3) Elliptical 4) Con/Span 5) Elevated Arch 6) Pipe Arch 7) Other	RCP (Reinforced Concrete Pipe) CMP (Corrugated Metal Pipe) Bitmus Coated Steel Timber Ductile Clay Masonry Rock	Height from Top of Road to Invert <u>Top of Road EL</u> From Topo Map (FT.NGVD) or (FT.NAVD)	Headwall Wingwalls Type 0°, 45°, <u>90°</u> Projecting Flush with Slope MES (Mitered End Section) FES (Flared End Section)

Pier Shape

- 1) Circular pier
- 2) Twin-Cylinder piers
- 3) Elongated pier
- 4) Triangular nose
- 5) Square nose



Types (Shape) of Culvert

- | | | |
|---|---|---|
|  |  |  |
| 1) Circular | <u>2) Rectangle</u> | 3) Elliptical |
|  |  |  |
| 4) Con/Span | 5) Elevated Arch | 6) Pipe Arch |
| 7) Other | | |

Inlet/Outlet Type

Culvert with Headwall & Wingwalls

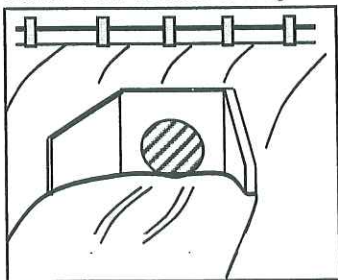

Mitered to Conform to Slope

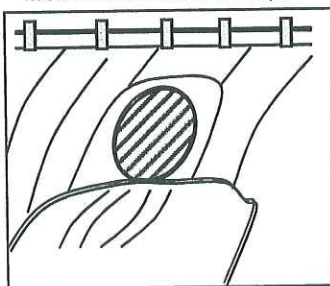

Projecting from Fill

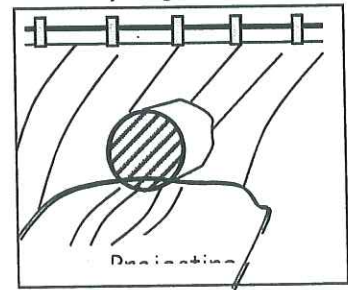

ADDITIONAL CHANNEL INFORMATION

Land Use Residential

Vegetative Cover _____

Bed Material _____

General Channel Condition Rectangular concrete-lined channel

Banks _____

Overbanks _____

STRUCTURE SURVEY TEMPLATE

				DATE	10-22-08
ROAD NAME	Powell Dr. & Everett Dr			COUNTY	LA
STREAM NAME	South Fork SCR			PHOTO ID #	
STRUCTURE #	75		X,Y COORDINATE		
TYPE	LENGTH	SIZE (W X H) & SHAPE	MATERIAL	Road to Bed	INLET/OUTLET TYPE
Railroad Bridge				Top of Road EL	
SPECIAL NOTE (Conditions, Blockage, etc)		Single long ^{curved} culv. / deeper than US bridges (Rise ~ 20'?)			
HIGH WATER MARK (Description, Witness, and Date)					
TYPE		CULVERT TYPE	MATERIAL	Road to Bed	INLET/OUTLET TYPE
Bridge Span Bridge Pier Shape <u>Culvert</u> Dam Millway Water Barrel Outlet		Number of Barrels 1) Circular 2) <u>Rectangle</u> (Span X Rise) 3) Elliptical 4) Con/Span 5) Elevated Arch 6) Pipe Arch 7) Other	<u>RCP</u> (Reinforced Concrete Pipe) CMP (Corrugated Metal Pipe) Bitmus Coated Steel Timber Ductile Clay Masonry Rock	Height from Top of Road to Invert <u>Top of Road EL</u> From Topo Map (FT.NGVD) or (FT.NAVD)	Headwall Wingwalls Type 0°, 45°, <u>90°</u> Projecting Flush with Slope MES (Mitered End Section) FES (Flared End Section)

Pier Shape

- 1) Circular pier
- 2) Twin-Cylinder piers
- 3) Elongated pier
- 4) Triangular nose
- 5) Square nose



Types (Shape) of Culvert

- | | | |
|-------------|------------------|---------------|
| | | |
| 1) Circular | 2) Rectangle | 3) Elliptical |
| | | |
| 4) Con/Span | 5) Elevated Arch | 6) Pipe Arch |
| 7) Other | | |

Inlet/Outlet Type

Culvert with Headwall & Wingwalls

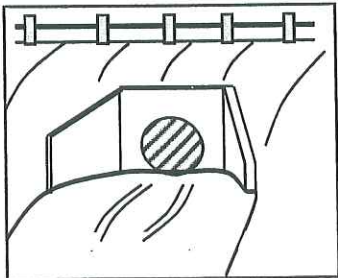

Mitered to Conform to Slope

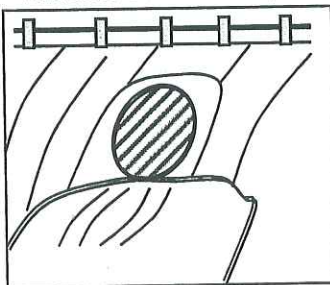

Projecting from Fill

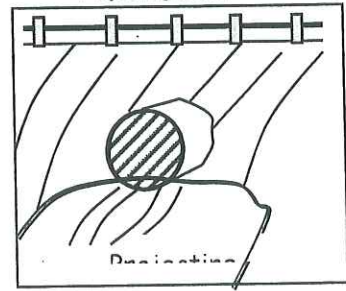

CHANNEL INFORMATION

ROAD TO BANK	CHANNEL TOP WIDTH	CHANNEL BOTTOM WIDTH

BRIDGE INFORMATION

DECK THICKNESS	TOP WIDTH	TOE WIDTH
HYDRAULIC WIDTH	NUMBER OF PIERS	PIER THICKNESS

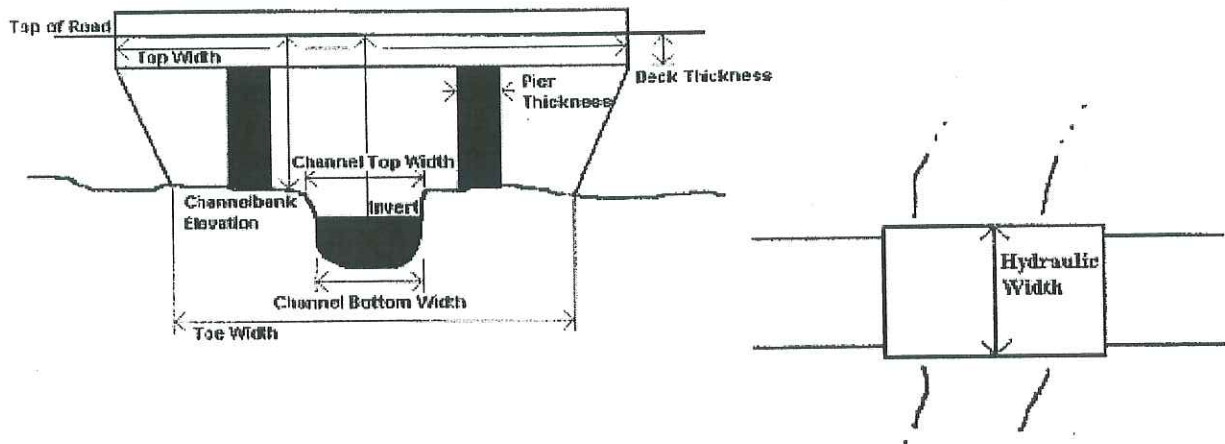

PHOTOS

Name

Description

--	--

ADDITIONAL CHANNEL INFORMATION

Land Use *Residential*

Vegetative Cover

Bed Material

General Channel Condition *Rectangular concrete-lined channel*

Banks

Overbanks

STRUCTURE SURVEY TEMPLATE

				DATE	10-22-08
ROAD NAME	Atwood Blvd.			COUNTY	LA
STREAM NAME	South Fork SCR			PHOTO ID #	
STRUCTURE #	6	X,Y COORDINATE			
TYPE	LENGTH	SIZE (W X H) & SHAPE	MATERIAL	Road to Bed	INLET/OUTLET TYPE
Railroad Bridge				Top of Road EL	
SPECIAL NOTE (Conditions, Blockage, etc)		Same as #3			
HIGH WATER MARK (Description, Witness, and Date)					
TYPE		CULVERT TYPE	MATERIAL	Road to Bed	INLET/OUTLET TYPE
Bridge <u>Span Bridge</u> Pier Shape Culvert Dam Millway User Barrel Outlet		Number of Barrels 1) Circular 2) Rectangle (Span X Rise) 3) Elliptical 4) Con/Span 5) Elevated Arch 6) Pipe Arch 7) Other	RCP (Reinforced Concrete Pipe) CMP (Corrugated Metal Pipe) Bitmus Coated Steel Timber Ductile Clay Masonry Rock	Height from Top of Road to Invert Top of Road EL From Topo Map (FT.NGVD) or (FT.NAVD)	Headwall Wingwalls Type 0°, 45°, 90° Projecting Flush with Slope MES (Mitered End Section) FES (Flared End Section)

Pier Shape

- 1) Circular pier
- 2) Twin-Cylinder piers
- 3) Elongated pier
- 4) Triangular nose
- 5) Square nose



Types (Shape) of Culvert

- | | | |
|-------------|------------------|---------------|
| | | |
| 1) Circular | 2) Rectangle | 3) Elliptical |
| | | |
| 4) Con/Span | 5) Elevated Arch | 6) Pipe Arch |
| 7) Other | | |

Inlet/Outlet Type

Culvert with Headwall & Wingwalls

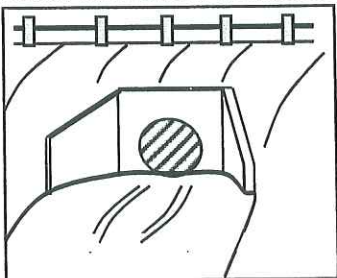

Mitered to Conform to Slope

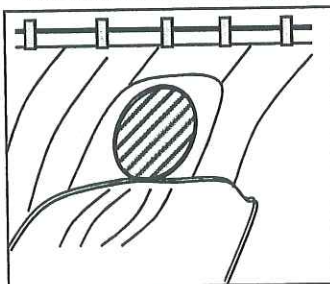

Projecting from Fill

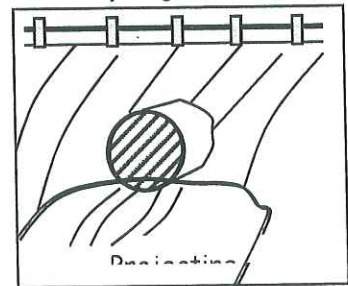

CHANNEL INFORMATION

ROAD TO BANK	CHANNEL TOP WIDTH	CHANNEL BOTTOM WIDTH

BRIDGE INFORMATION

DECK THICKNESS	TOP WIDTH	TOE WIDTH
HYDRAULIC WIDTH	NUMBER OF PIERS	PIER THICKNESS

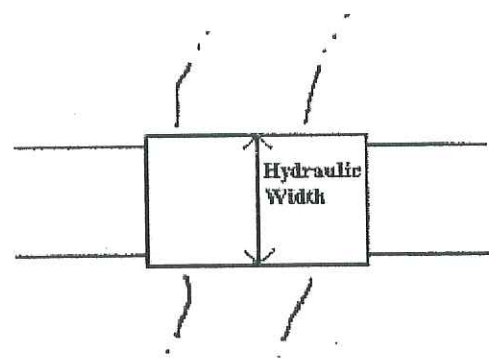
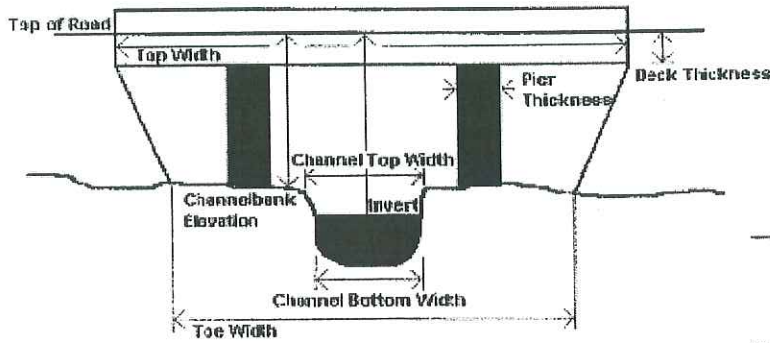

PHOTOS

Name

Description

Empty space for providing photos and descriptions.

ADDITIONAL CHANNEL INFORMATION

Land Use Residential

Vegetative Cover _____

Bed Material Concrete - lined

General Channel Condition Rectangular channel

Banks _____

Overbanks _____

STRUCTURE SURVEY TEMPLATE







				DATE	10-22-08
JAD NAME	De Wolfe Rd			COUNTY	LA
STREAM NAME	South Fork SCR			PHOTO ID #	
STRUCTURE #	57		X,Y COORDINATE		
TYPE	LENGTH	SIZE (W X H) & SHAPE	MATERIAL	Road to Bed	INLET/OUTLET TYPE
Railroad Bridge				Top of Road EL	
SPECIAL NOTE (Conditions, Blockage, etc)		Same as # 3			
HIGH WATER MARK (Description, Witness, and Date)					
TYPE		CULVERT TYPE	MATERIAL	Road to Bed	INLET/OUTLET TYPE
Bridge <u>Span Bridge</u> Pier Shape Culvert Dam Millway User Barrel Outlet		Number of Barrels 1) Circular 2) Rectangle (Span X Rise) 3) Elliptical 4) Con/Span 5) Elevated Arch 6) Pipe Arch 7) Other	RCP (Reinforced Concrete Pipe) CMP (Corrugated Metal Pipe) Bitmus Coated Steel Timber Ductile Clay Masonry Rock	Height from Top of Road to Invert <u>Top of Road EL</u> From Topo Map (FT.NGVD) or (FT.NAVD)	Headwall Wingwalls Type 0°, 45°, 90° Projecting Flush with Slope MES (Mitered End Section) FES (Flared End Section)

Pier Shape

- 1) Circular pier
- 2) Twin-Cylinder piers
- 3) Elongated pier
- 4) Triangular nose
- 5) Square nose



Types (Shape) of Culvert

- | | | |
|---|---|---|
|  |  |  |
| 1) Circular | 2) Rectangle | 3) Elliptical |
|  |  |  |
| 4) Con/Span | 5) Elevated Arch | 6) Pipe Arch |
| 7) Other | | |

Inlet/Outlet Type

Culvert with Headwall & Wingwalls

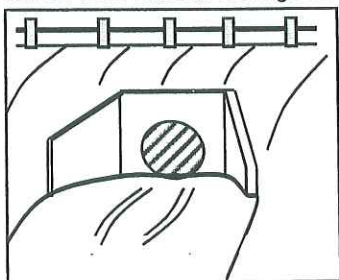

Mitered to Conform to Slope

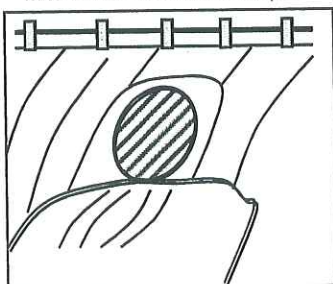

Projecting from Fill

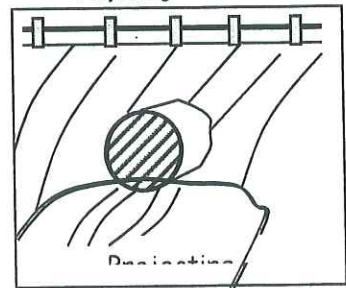

CHANNEL INFORMATION

ROAD TO BANK	CHANNEL TOP WIDTH	CHANNEL BOTTOM WIDTH

BRIDGE INFORMATION

DECK THICKNESS	TOP WIDTH	TOE WIDTH
HYDRAULIC WIDTH	NUMBER OF PIERS	PIER THICKNESS

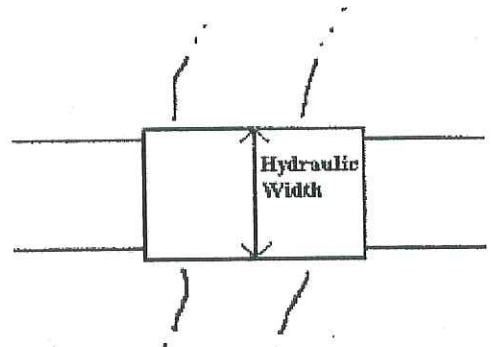
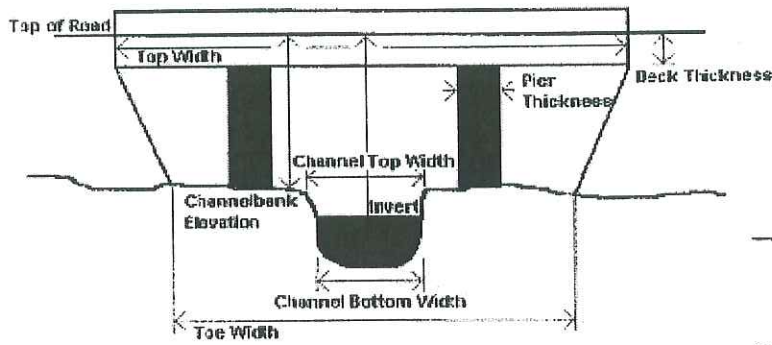

PHOTOS

Name

Description

Name	Description	PHOTOS

ADDITIONAL CHANNEL INFORMATION

Land Use Residential

Vegetative Cover _____

Bed Material Concrete - lined

General Channel Condition Rectangular channel

Banks _____

Overbanks _____

STRUCTURE SURVEY TEMPLATE







				DATE	10-22-08
ROAD NAME	Old Wiley Canyon			COUNTY	LA
STREAM NAME	South Fork SCR			PHOTO ID #	
STRUCTURE #	48		X, Y COORDINATE		
TYPE	LENGTH	SIZE (W X H) & SHAPE	MATERIAL	Road to Bed	INLET/OUTLET TYPE
Railroad Bridge				Top of Road EL	
SPECIAL NOTE (Conditions, Blockage, etc)		Span Bridge / same dimension as #3			
HIGH WATER MARK (Description, Witness, and Date)					
TYPE		CULVERT TYPE	MATERIAL	Road to Bed	INLET/OUTLET TYPE
Bridge <u>Span Bridge</u> Pier Shape Culvert Dam Millway User Barrel Outlet		Number of Barrels 1 1) Circular <u>2) Rectangle</u> (Span X Rise) 3) Elliptical 4) Con/Span 5) Elevated Arch 6) Pipe Arch 7) Other	<u>RCP</u> (Reinforced Concrete Pipe) CMP (Corrugated Metal Pipe) Bitmus Coated Steel Timber Ductile Clay Masonry Rock	Height from Top of Road to Invert <u>Top of Road EL</u> From Topo Map (FT.NGVD) or (FT.NAVD)	Headwall Wingwalls Type 0°, 45°, <u>90°</u> Projecting Flush with Slope MES (Mitered End Section) FES (Flared End Section)

Pier Shape

- 1) Circular pier
- 2) Twin-Cylinder piers
- 3) Elongated pier
- 4) Triangular nose
- 5) Square nose



Types (Shape) of Culvert

- | | | |
|---|---|---|
|  |  |  |
| 1) Circular | 2) Rectangle | 3) Elliptical |
|  |  |  |
| 4) Con/Span | 5) Elevated Arch | 6) Pipe Arch |
| 7) Other | | |

Inlet/Outlet Type

Culvert with Headwall & Wingwalls

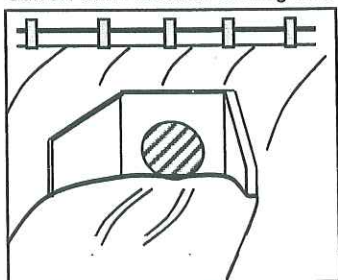

Mitered to Conform to Slope

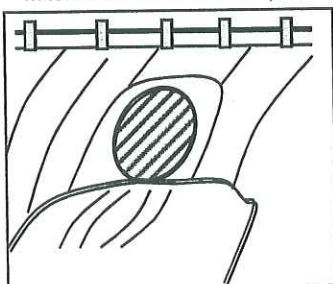

Projecting from Fill

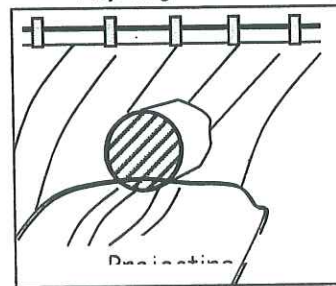

CHANNEL INFORMATION

ROAD TO BANK	CHANNEL TOP WIDTH	CHANNEL BOTTOM WIDTH

BRIDGE INFORMATION

DECK THICKNESS	TOP WIDTH	TOE WIDTH
HYDRAULIC WIDTH	NUMBER OF PIERS	PIER THICKNESS

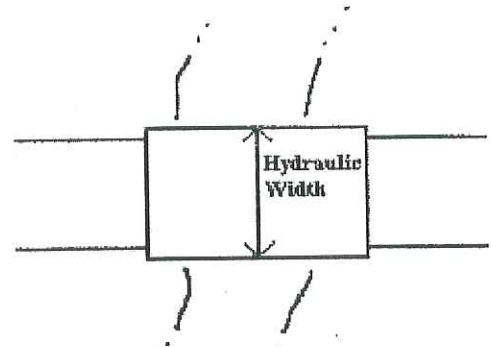
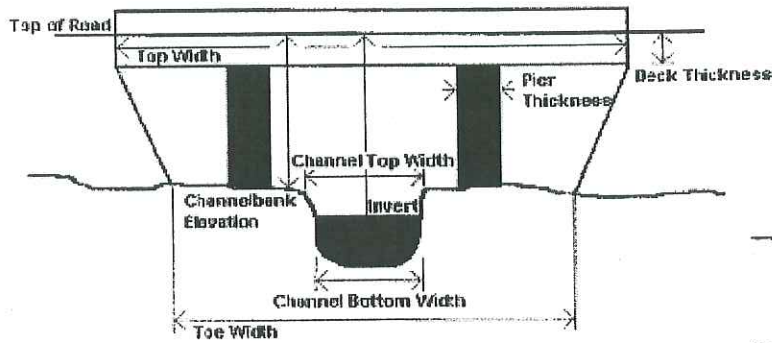

PHOTOS

Name

Description

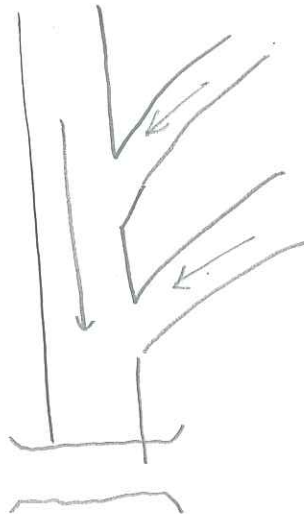

ADDITIONAL CHANNEL INFORMATION

Land Use Residential + Open space

Vegetative Cover _____

Bed Material _____

General Channel Condition Rectangular
Concrete-lined channel

Banks _____

Overbanks _____

STRUCTURE SURVEY TEMPLATE







				DATE	10-22-08
ROAD NAME	Wiley Rd			COUNTY	LA
STREAM NAME	South Fork SCR			PHOTO ID #	
STRUCTURE #	39	X,Y COORDINATE			
TYPE	LENGTH	SIZE (W X H) & SHAPE	MATERIAL	Road to Bed	INLET/OUTLET TYPE
Railroad Bridge				Top of Road EL	
SPECIAL NOTE (Conditions, Blockage, etc)		Span Bridge / No measurement			
HIGH WATER MARK (Description, Witness, and Date)					
TYPE		CULVERT TYPE	MATERIAL	Road to Bed	INLET/OUTLET TYPE
Bridge Span Bridge Pier Shape Culvert Dam Millway Inlet Barrel Outlet		Number of Barrels 1 1) Circular 2) Rectangle (Span X Rise) 3) Elliptical 4) Con/Span 5) Elevated Arch 6) Pipe Arch 7) Other	RCP (Reinforced Concrete Pipe) CMP (Corrugated Metal Pipe) Bitmus Coated Steel Timber Ductile Clay Masonry Rock	Height from Top of Road to Invert Top of Road EL From Topo Map (FT.NGVD) or (FT.NAVD)	Headwall Wingwalls Type 0°, 45°, 90° Projecting Flush with Slope MES (Mitered End Section) FES (Flared End Section)

Pier Shape

- 1) Circular pier
- 2) Twin-Cylinder piers
- 3) Elongated pier
- 4) Triangular nose
- 5) Square nose



Types (Shape) of Culvert

- | | | |
|---|---|---|
|  |  |  |
| 1) Circular | 2) Rectangle | 3) Elliptical |
|  |  |  |
| 4) Con/Span | 5) Elevated Arch | 6) Pipe Arch |
| 7) Other | | |

Inlet/Outlet Type

Culvert with Headwall & Wingwalls

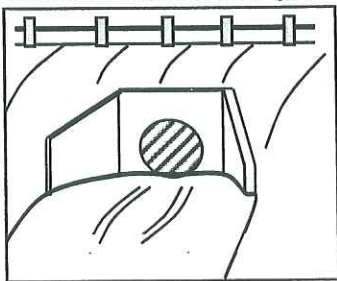

Mitered to Conform to Slope

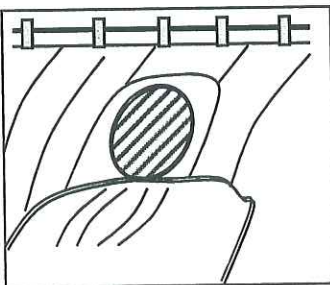

Projecting from Fill

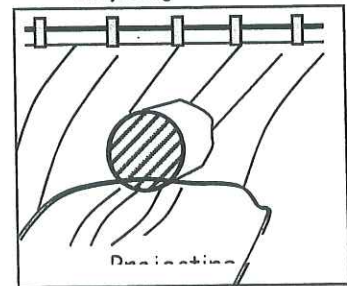

CHANNEL INFORMATION

ROAD TO BANK	CHANNEL TOP WIDTH	CHANNEL BOTTOM WIDTH

BRIDGE INFORMATION

DECK THICKNESS	TOP WIDTH	TOE WIDTH
HYDRAULIC WIDTH	NUMBER OF PIERS	PIER THICKNESS

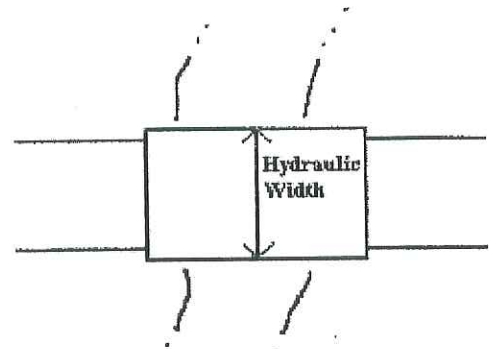
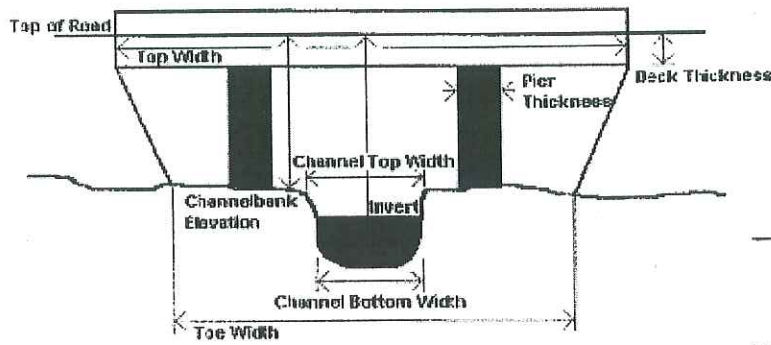

PHOTOS

Name

Description

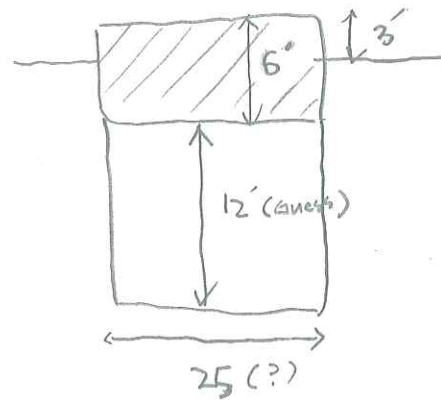
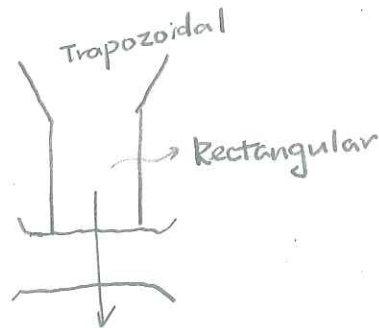

ADDITIONAL CHANNEL INFORMATION

Land Use *Residential + Open space*

Vegetative Cover

Bed Material

General Channel Condition *Concrete-lined*

Banks

Overbanks

STRUCTURE SURVEY TEMPLATE

				DATE	10-22-08
ROAD NAME	I-5			COUNTY	LA
STREAM NAME	South Fork SCR			PHOTO ID #	
STRUCTURE #	7 10		X,Y COORDINATE		
TYPE	LENGTH	SIZE (W X H) & SHAPE	MATERIAL	Road to Bed	INLET/OUTLET TYPE
Railroad Bridge				Top of Road EL	
SPECIAL NOTE (Conditions, Blockage, etc)		3 - 12' x 8' Box Culv. → due to sedimentation (originally 10' c?)			
HIGH WATER MARK (Description, Witness, and Date)					
TYPE		CULVERT TYPE	MATERIAL	Road to Bed	INLET/OUTLET TYPE
Bridge Span Bridge Pier Shape Culvert Dam Millway Trough Barrel Outlet		Number of Barrels 3 1) Circular 2) Rectangle (Span X Rise) 3) Elliptical 4) Con/Span 5) Elevated Arch 6) Pipe Arch 7) Other	RCP (Reinforced Concrete Pipe) CMP (Corrugated Metal Pipe) Bitumus Coated Steel Timber Ductile Clay Masonry Rock	Height from Top of Road to Invert Top of Road EL From Topo Map (FT.NGVD) or (FT.NAVD)	Headwall Wingwalls Type 0°, 45°, 90° Projecting Flush with Slope MES (Mitered End Section) FES (Flared End Section)

Pier Shape

- 1) Circular pier
- 2) Twin-Cylinder piers
- 3) Elongated pier
- 4) Triangular nose
- 5) Square nose



1) Circular



Types (Shape) of Culvert

2) Rectangle



3) Elliptical



4) Con/Span

5) Elevated Arch

6) Pipe Arch

7) Other

Inlet/Outlet Type

Culvert with Headwall & Wingwalls

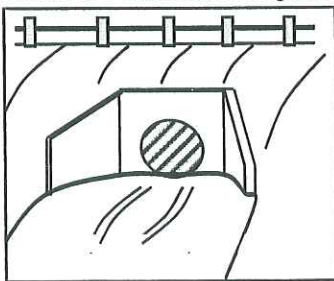

Mitered to Conform to Slope

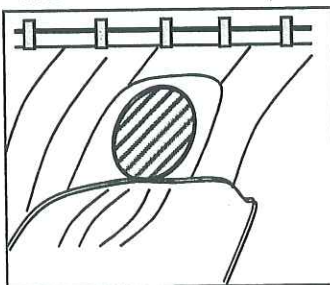

Projecting from Fill

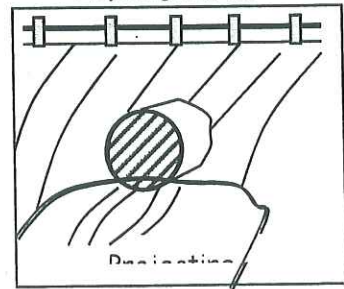

CHANNEL INFORMATION

ROAD TO BANK	CHANNEL TOP WIDTH	CHANNEL BOTTOM WIDTH

BRIDGE INFORMATION

DECK THICKNESS	TOP WIDTH	TOE WIDTH
2'		
HYDRAULIC WIDTH	NUMBER OF PIERS	PIER THICKNESS

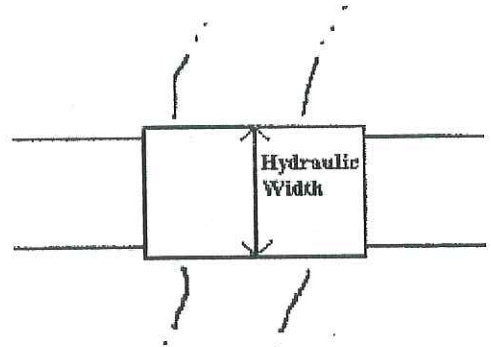
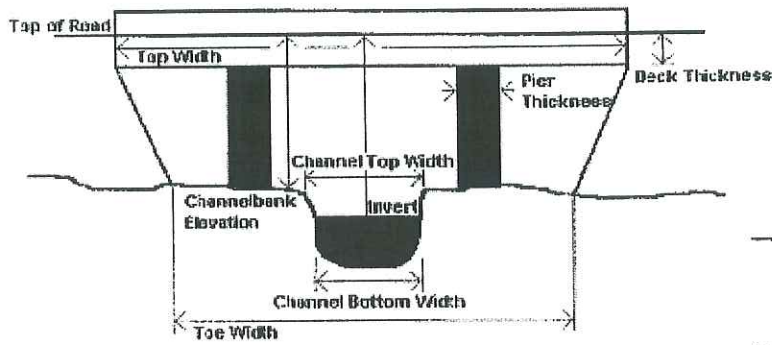

PHOTOS

Name

Description

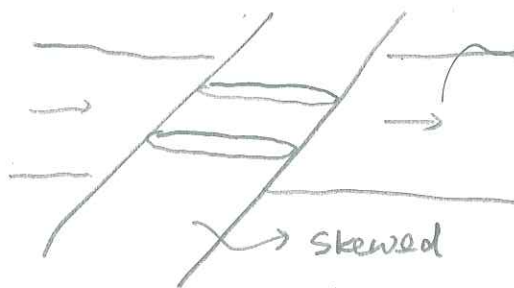

highly vegetated DS side

sedimentation at the bottom of the culv.

ADDITIONAL CHANNEL INFORMATION

Land Use Open space / Brush

Vegetative Cover _____

Bed Material Gravel + Sand

General Channel Condition _____

Banks _____

Overbanks _____

STRUCTURE SURVEY TEMPLATE





				DATE	10-22-08
ROAD NAME	Calgrove Blvd.			COUNTY	LA
STREAM NAME	South Fork SCR			PHOTO ID #	
STRUCTURE #	+ 11		X,Y COORDINATE		
TYPE	LENGTH	SIZE (W X H) & SHAPE	MATERIAL	Road to Bed	INLET/OUTLET TYPE
Railroad Bridge				Top of Road EL	
SPECIAL NOTE (Conditions, Blockage, etc)		Confluence w/ Towstey 3-12'x10' Box Culv.			
HIGH WATER MARK (Description, Witness, and Date)					
TYPE		CULVERT TYPE	MATERIAL	Road to Bed	INLET/OUTLET TYPE
Bridge Span Bridge Pier Shape <u>Culvert</u> Dam Millway User Barrel Outlet		Number of Barrels 3 1) Circular 2) <u>Rectangle</u> (Span X Rise) 3) Elliptical 4) Con/Span 5) Elevated Arch 6) Pipe Arch 7) Other	<u>RCP</u> (Reinforced Concrete Pipe) CMP (Corrugated Metal Pipe) Bitmus Coated Steel Timber Ductile Clay Masonry Rock	Height from Top of Road to Invert <u>Top of Road EL</u> From Topo Map (FT.NGVD) or (FT.NAVD)	Headwall <u>Wingwalls</u> Type 0°, 45°, <u>90°</u> Projecting Flush with Slope MES (Mitered End Section) FES (Flared End Section)

Pier Shape

- 1) Circular pier
- 2) Twin-Cylinder piers
- 3) Elongated pier
- 4) Triangular nose
- 5) Square nose

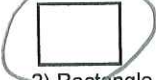

Types (Shape) of Culvert

- | | | |
|---|---|---|
|  |  |  |
| 1) Circular | 2) <u>Rectangle</u> | 3) Elliptical |
|  |  |  |
| 4) Con/Span | 5) Elevated Arch | 6) Pipe Arch |
| 7) Other | | |

Inlet/Outlet Type

Culvert with Headwall & Wingwalls

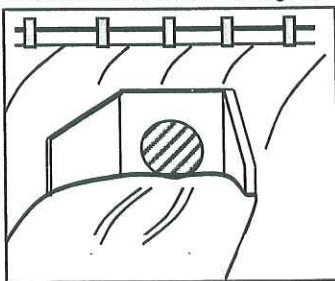

Mitered to Conform to Slope

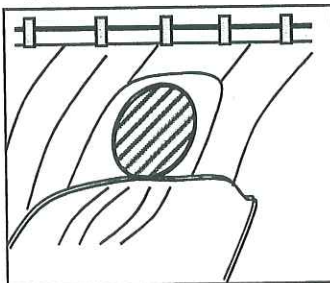

Projecting from Fill

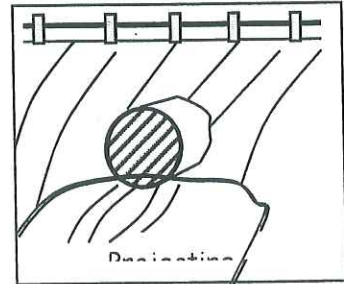

CHANNEL INFORMATION

ROAD TO BANK	CHANNEL TOP WIDTH	CHANNEL BOTTOM WIDTH

BRIDGE INFORMATION

DECK THICKNESS	TOP WIDTH	TOE WIDTH
2'		
HYDRAULIC WIDTH	NUMBER OF PIERS	PIER THICKNESS

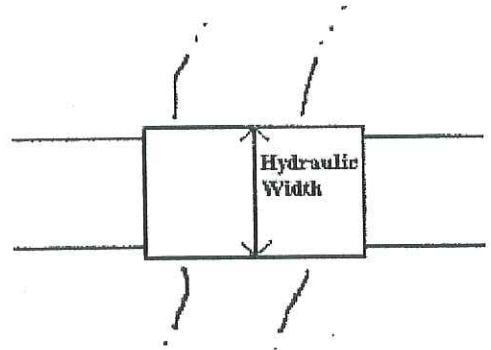
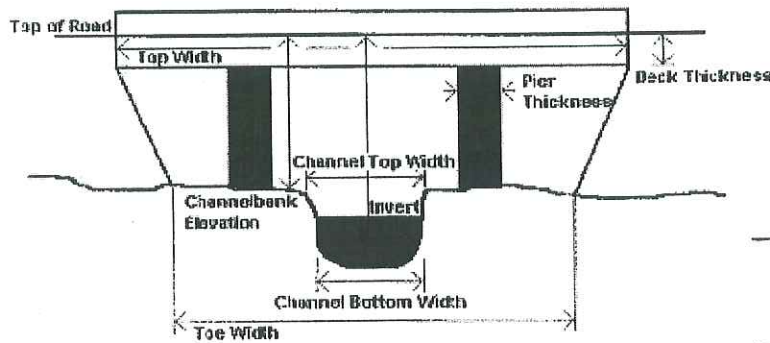

PHOTOS

Name

Description

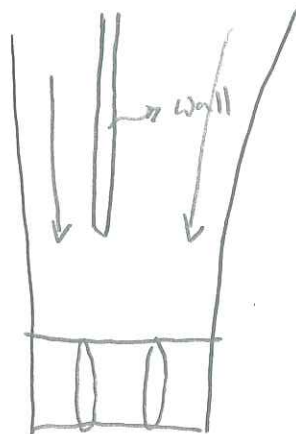

Sedimentation at the bottom of culv.

ADDITIONAL CHANNEL INFORMATION

Land Use Open space / Brush

Vegetative Cover _____

Bed Material Concrete - lined

General Channel Condition rec concrete - lined channel

Banks _____

Overbanks _____